

Technical Data

Model	BELT DRIVE	ACS 22	ACK 33 (WEAVING)
Fan Motor	1.5 / 2.2 kw	2.2 kw	4 kw
Traverse Motor		150 W	160 W
Traveling Speed	12 mtr./min.	12/16 mtr./min.	12/16 mtr./min.
Air Volume	1800 - 2200 M ³ /hr	3450 M ³ /hr	5000 M ³ /hr
Suction Capacity	2250 - 2700 Pa	2600 Pa	3600 Pa
No of Blowing Pipes	2x125 mm	2x125 mm	12x75 mm
No of Suction Pipes	4x125 mm Dia	4x125 mm Dia	4x125 mm Dia
Filter Size	0.18 Sq.m	0.216 Sq.m	0.216 Sq.m
Machine Operation	AUTOMATIC	PLC CONTROLLED	PLC CONTROLLED

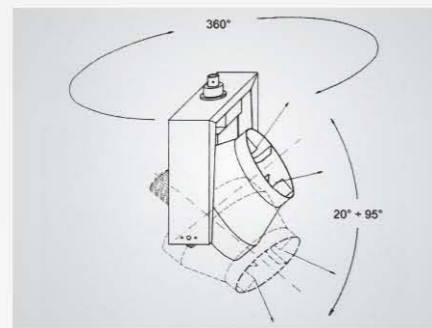

Globus



TECHNICAL FEATURES
 Weight : kg 57
 Voltage :
 V 220/240 - 380/420
 Installed power : kw 0,6
 3600 rotation : n. 7,5/h
 Oscillations : up to n. 60/h
 Capacity : cu.m./h 6000
 Action range : m. 10-12

Particularly suitable for textile environments, the Globus fan prevents accumulation of lint and dust on ceiling, overhead beams, lighting, pipes, ducts and over automatic transport systems.



Latest Italian Technology to achieve the Best of Efficiency, Manufactured by Perfect in technical collaboration with magitex s.r.l. 21020 mornago (VA) Italy.

The information given in this leaflet is as accurate as possible with our present technical knowledge. All pictures and data is illustrative and provided for guideline only. PERFECT ENGINEERING CORPORATION reserves the right to alter or amend any specification without notice.



PERFECT ENGINEERING CORPORATION

Plot No. 509, G.I.D.C. Estate, Odhav, Ahmedabad - 382 415, INDIA.
 Ph. : +91-79-22871516, 22890895, Fax : +91-79-22870307
 E-mail : sales@perfectequipments.com Website: www.perfectindia.com



The best cleaning solution for all textile machines

- Simple Design & Robust Construction
- Low installed power with high performance fan
- Top quality components makes the unit extremely reliable.



Power systems are available according to type of installation :



Energy Chain



Belt Drive



Over Head Cleaner for Winding(Belt Drive)



Over Head Cleaner for other Application



Over Head Cleaner for Speed Frame



Wonder Cleaner to remove spindle under winding

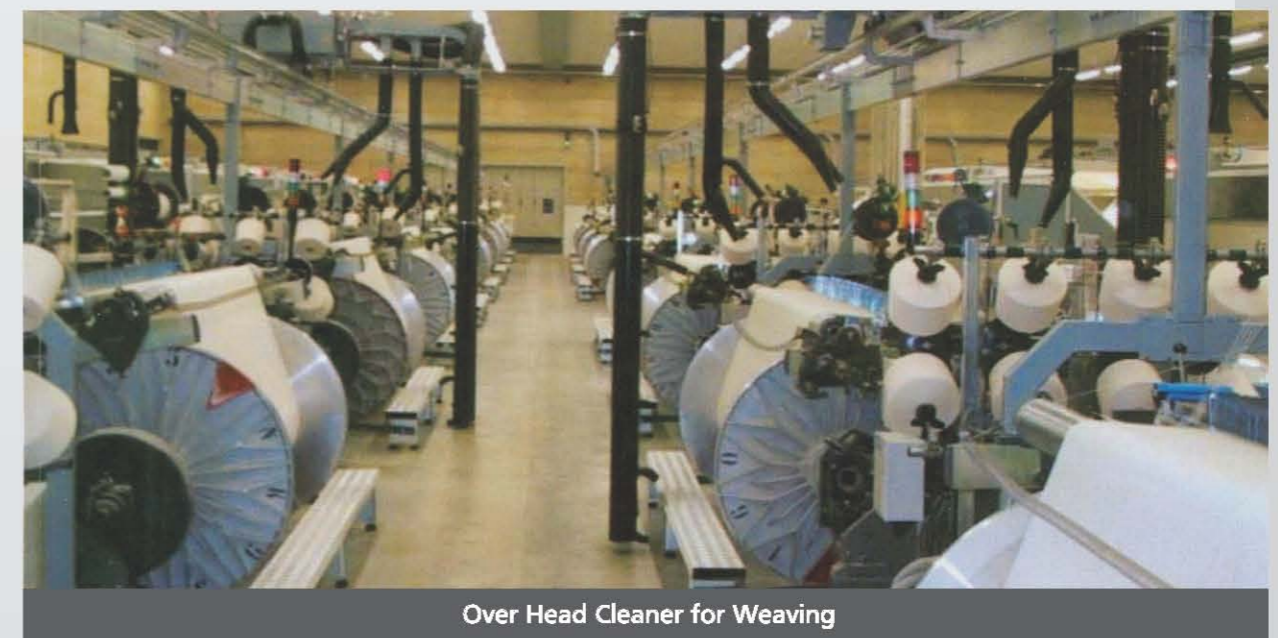

Over Head Cleaner for Weaving